

COUP D'ETAT



Noble Lamp
by Entrelacs
Contemporary
United States

Bronze patinated table lamp with alabaster diffuser.
Available in 226, 295 and 365mm diameters.

8.9" Dia. (226 mm)
LC-ENTRELACS-NOMAD 226

11.61" Dia. (295 mm)
LC-ENTRELACS-HUBLOT 295

14.37" Dia. (365 mm)
LC-ENTRELACS-HUBLOT 365

111 Rhode Island Street, Suite 1 San Francisco, CA 94103 P. 415 241 9300
100 N Robertson Blvd, Los Angeles, CA 90048 P. 323 825 5880
E. info@coupdetatsf.com COUPDETATSF.COM

NOBLE 226 BY ENTRELACS

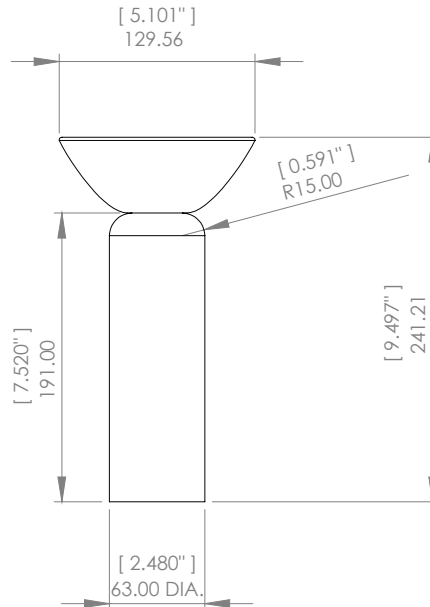

FRONT

ITEM NO.	DIMENSIONS	LUMENS	1300 LM (NOMINAL)
LC-ENTRELACS-NOMAD 226	5.1" DIA X 9.5" H	WATTS	36 W

DESCRIPTION

BRONZE PATINATED TABLE LAMP WITH ALABASTER DIFFUSER.

BRONZE FINISH OPTIONS*

RAW FNRB
MEDIUM BROWN FNMB
BLACK FNBK
LIGHT MARBLE FNLMB

*PLEASE NOTE THAT THE BRONZE HAS A LIVING FINISH. A CLEAR COAT CAN BE APPLIED IF SPECIFIED TO AVOID PATINA.

ALABASTER OPTIONS

WHITE VEINED
BROWN VEINED

SPECIFICATIONS

CLASS :2

PROTECTION : IP44

MAIN POWER : I20 - 277 V - 50 HZ

LIGHTING : XICATO® LED MODULE
1 - 10 V + BLE - 48 V - 36 W -
1300 LUMENS (NOMINAL)

COLOR : 2700 K, 3000 K, 3500 K

DRIVER : INTGR (DIMMABLE)
/INSIDE (DIMMABLE)

CORDLENGTH: 2000MM

WEIGHT : 2, 7 KG / 6 LB

CERTIFICATES



STANDARD



OPTIONS



COLORS



VARIATION DIMMING



* FACTORY SETTING

ADDITIONAL INFO

BODY LAMP PATINATES BRONZE - PROTECTIVE VARNISH - ALABASTER DIFFUSER, DIMMABLE LIGHT WITH KNOB 220-240V / 50-60HZ / 48V - LED CANNOT BE CHANGED / 36W

NOBLE 295 BY ENTRELACS

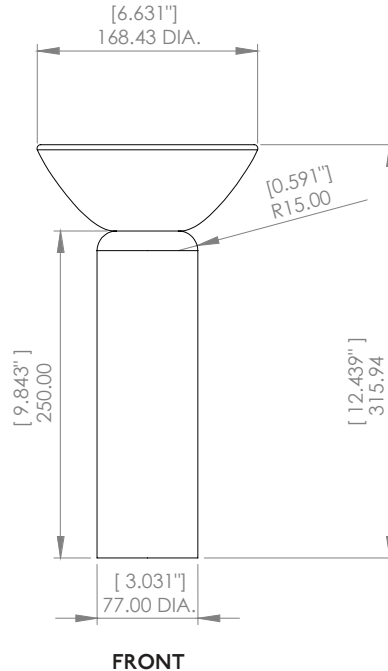

ITEM NO.	DIMENSIONS	LUMENS	2000 LM (NOMINAL)
LC-ENTRELACS-HUBLOT 295	6.63" DIA. x 12.44" H	WATTS	36 W

DESCRIPTION

BRONZE PATINATED TABLE LAMP WITH ALABASTER DIFFUSER.

BRONZE FINISH OPTIONS*

RAW FNRB
MEDIUM BROWN FNMB
BLACK FNBK
LIGHT MARBLE FNLMB

*PLEASE NOTE THAT THE BRONZE HAS A LIVING FINISH. A CLEAR COAT CAN BE APPLIED IF SPECIFIED TO AVOID PATINA.

ALABASTER OPTIONS

WHITE VEINED
BROWN VEINED

SPECIFICATIONS

CLASS : 2

PROTECTION : IP44

MAIN POWER : 220 - 240 V - 50 / 60 HZ

LIGHTING : XICATO® LED MODULE
1 - 10 V + BLE - 48 V - 36 W - 2000 LUMENS (NOMINAL)

COLOR : 2700K, 3000K, 4000K

DRIVER : INTGR (DIMMABLE)
/ INSIDE (DIMMABLE)

CORDLENGTH: 2000MM

WEIGHT : 3,7 KG / 8 LB

CERTIFICATES



STANDARD



OPTIONS



COLORS



VARIATION DIMMING



* FACTORY SETTING

ADDITIONAL INFO

BODY LAMP PATINATES BRONZE - PROTECTIVE VARNISH - ALABASTER DIFFUSER, DIMMABLE LIGHT WITH KNOB 220-240V / 50-60HZ / 48V - LED CANNOT BE CHANGED / 36W

NOBLE 365 BY ENTRELACS

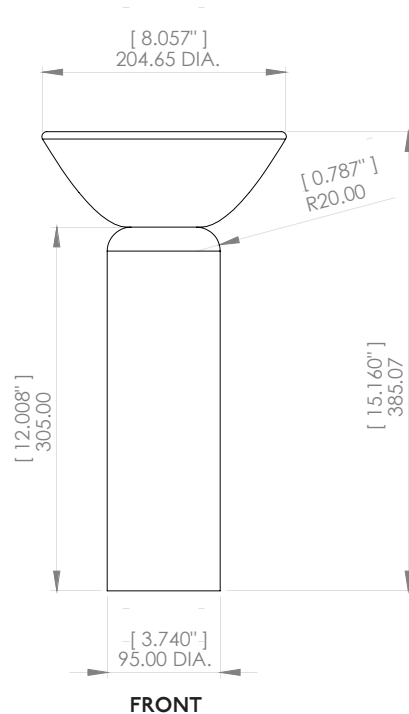

ITEM NO.	DIMENSIONS	LUMENS	3000 LM (NOMINAL)
LC-ENTRELACS-NOBLE 365	8.057" DIA. X 15.16" H	WATTS	36 W

DESCRIPTION

BRONZE CEILING LIGHT WITH AN ALABASTER DIFFUSER.

BRONZE FINISH OPTIONS*

- RAW FNRB
- MEDIUM BROWN FNMB
- BLACK FNBK
- LIGHT MARBLE FNLMB

*PLEASE NOTE THAT THE BRONZE HAS A LIVING FINISH. A CLEAR COAT CAN BE APPLIED IF SPECIFIED TO AVOID PATINA.

ALABASTER OPTIONS

- WHITE VEINED
- BROWN VEINED

SPECIFICATIONS

CLASS : 2
PROTECTION : IP44
MAIN POWER : 50-60HZ
LIGHTING : XICATO® LED MODULE
 1 - 10 V + BLE - 48 V - 36 W - 3000 LUMENS (NOMINAL)
COLOR : 2700 K, 3000 K, 3500 K
DRIVER : D PORT (DIMMABLE), INTGR (DIMMABLE)/ OUTSIDE (DIMMABLE) , INSIDE (DIMMABLE)
WEIGHT : 26 KG / 57 LB .

CERTIFICATES



STANDARD



OPTIONS



COLORS



VARIATION DIMMING



* FACTORY SETTING

ADDITIONAL INFO

BODY LAMP PATINATES BRONZE - PROTECTIVE VARNISH - ALABASTER DIFFUSER, DIMMABLE LIGHT WITH KNOB 220-240V / 50-60HZ / 48V - LED CANNOT BE CHANGED / 36W